



US 20140225078A1

(19) **United States**

(12) **Patent Application Publication**  
**Jeung et al.**

(10) **Pub. No.: US 2014/0225078 A1**  
(43) **Pub. Date: Aug. 14, 2014**

(54) **ORGANIC LIGHT EMITTING DISPLAY DEVICE**

(52) **U.S. Cl.**  
CPC ..... *H01L 51/5206* (2013.01); *H01L 51/5221* (2013.01)  
USPC ..... **257/40**

(71) Applicant: **Samsung Display Co., LTD.**,  
Yongin-City (KR)

(72) Inventors: **Jun-Heyung Jeung**, Yongin-City (KR);  
**Tae-Jin Kim**, Yongin-City (KR)

(73) Assignee: **Samsung Display Co., LTD.**,  
Yongin-City (KR)

(21) Appl. No.: **13/970,549**

(22) Filed: **Aug. 19, 2013**

(30) **Foreign Application Priority Data**

Feb. 12, 2013 (KR) ..... 10-2013-0014971

**Publication Classification**

(51) **Int. Cl.**  
*H01L 51/52* (2006.01)

(57) **ABSTRACT**

An organic light emitting display device includes a plurality of first sub-pixels arranged adjacent to each other along a first direction, each of the first sub-pixels includes a first emission region configured to emit light of a first color and a first transmission region configured to transmit external light, the first emission regions of at least two of the first sub-pixels are adjacent to each other; and a plurality of second sub-pixels arranged adjacent to each other along the first direction and adjacent to corresponding ones of the plurality of first sub-pixels along a second direction crossing the first direction, each of the plurality of second sub-pixels includes a second emission region configured to emit light of a second color and a second transmission region configured to transmit external light, the second emission regions of at least two of the sub-pixels are adjacent to each other.

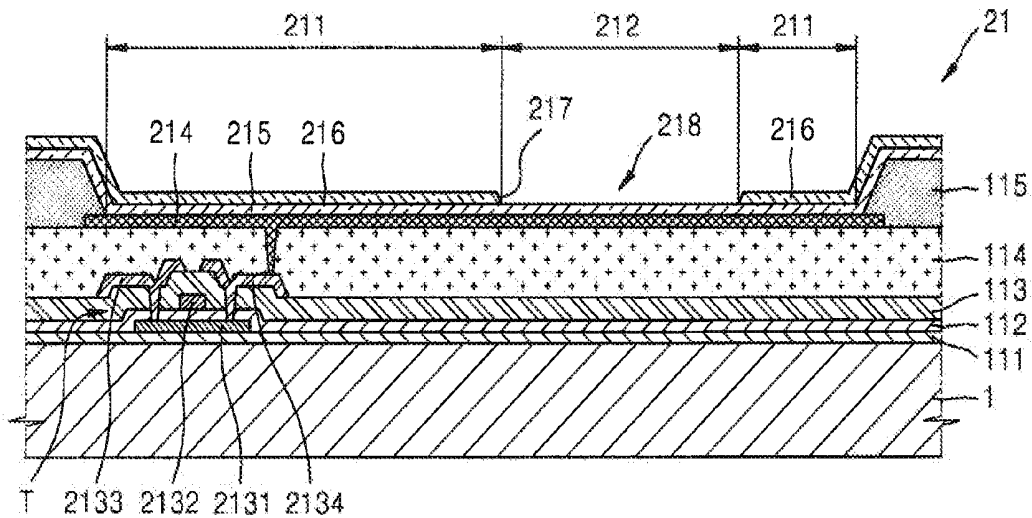

FIG. 1

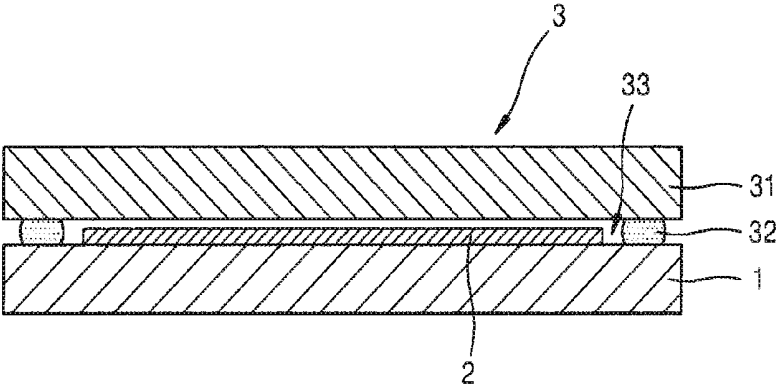

FIG. 2

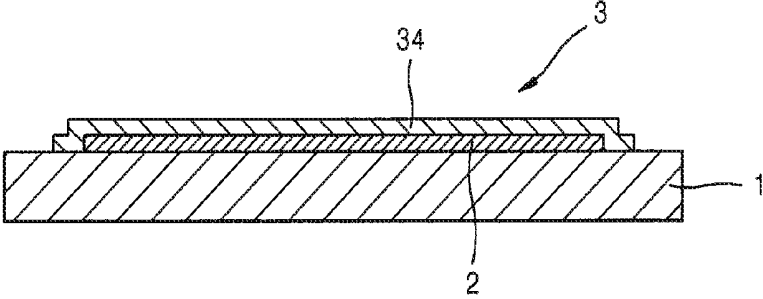

FIG. 3

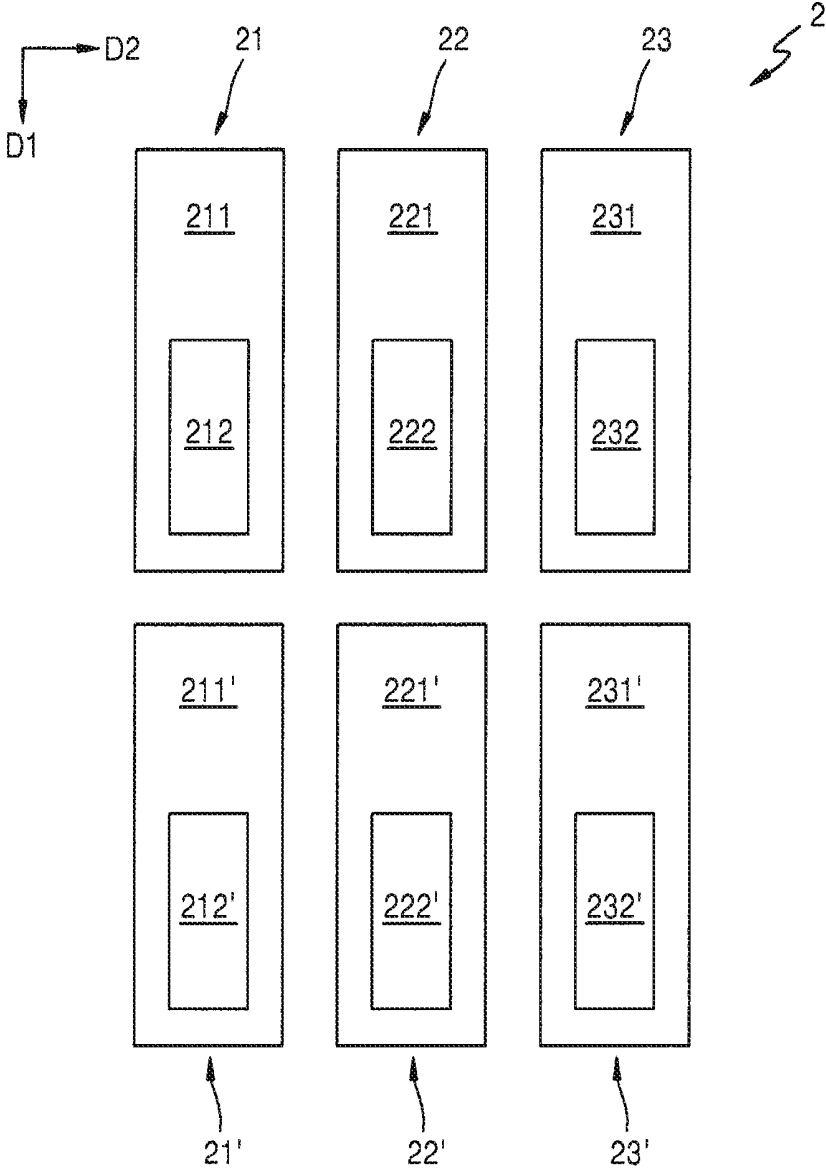



FIG. 5

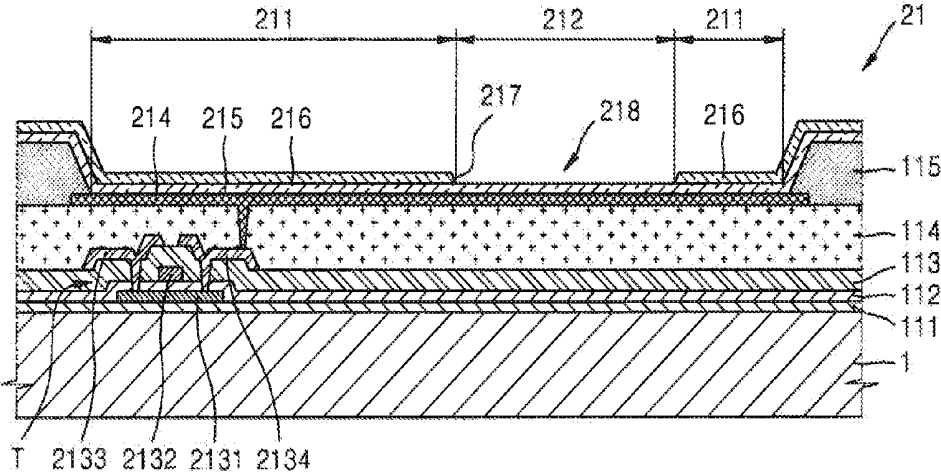

FIG. 6

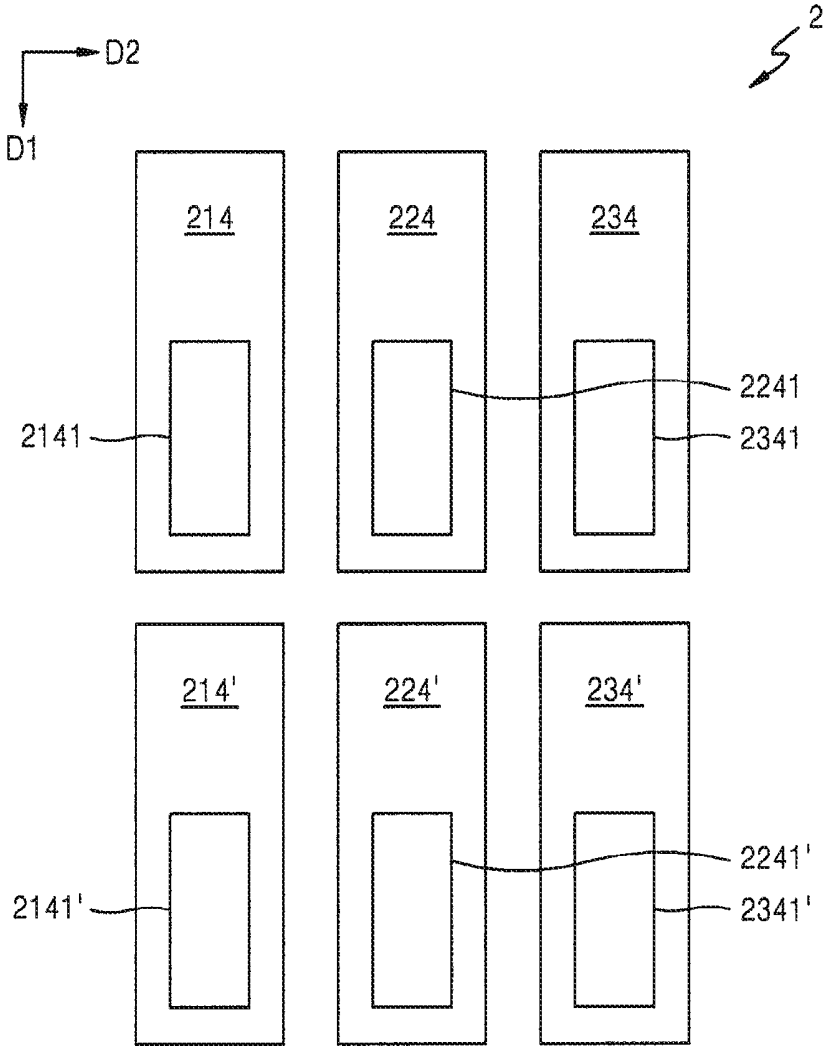

FIG. 7

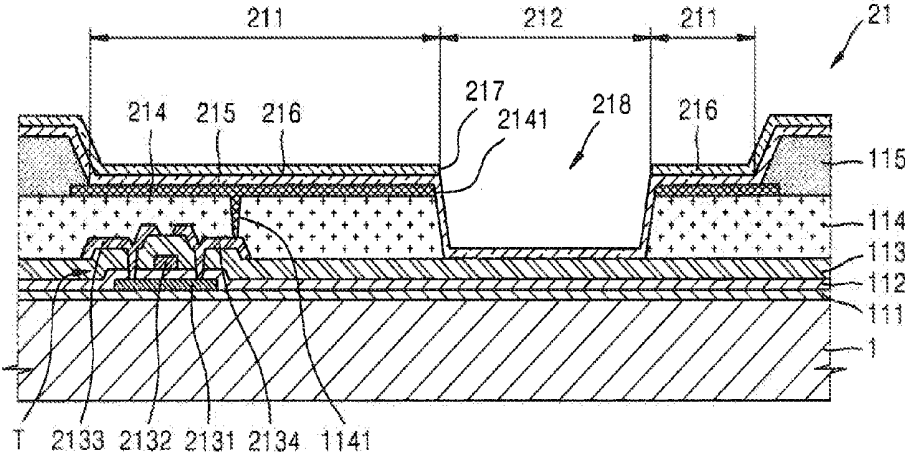

FIG. 8

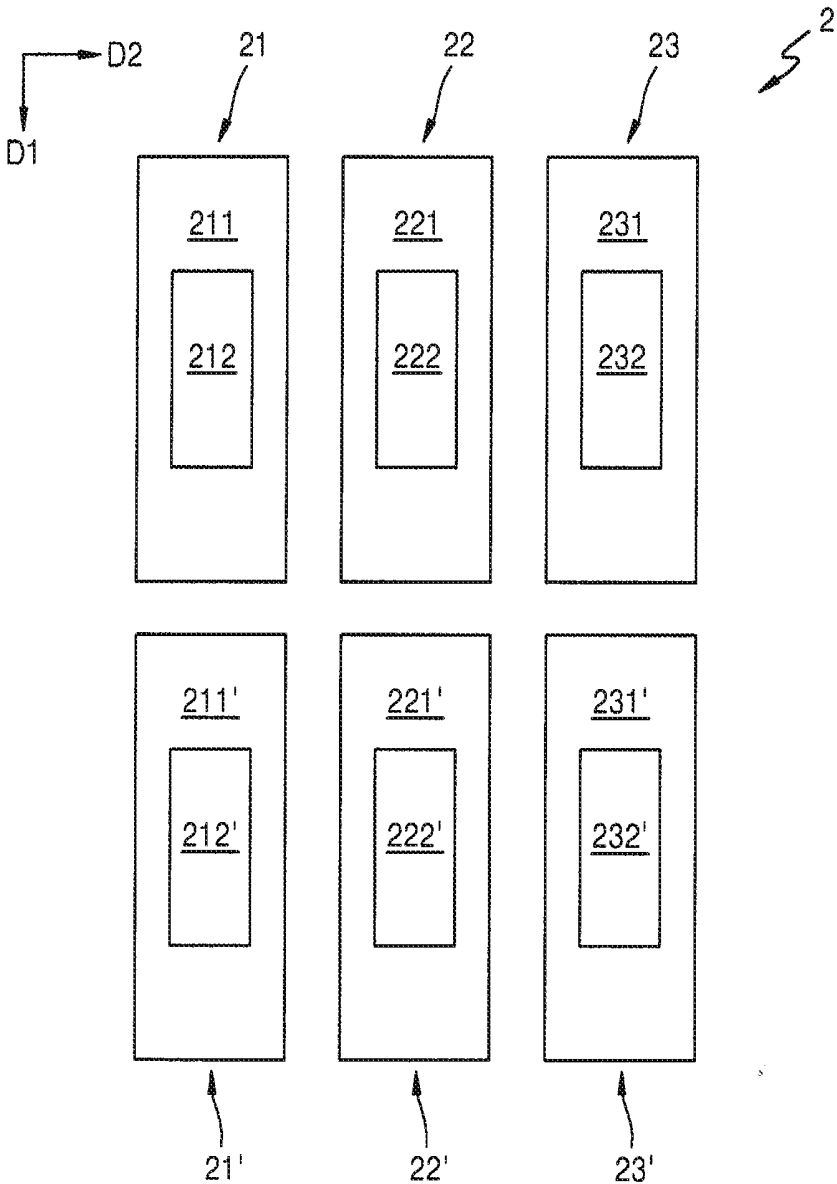

FIG. 9

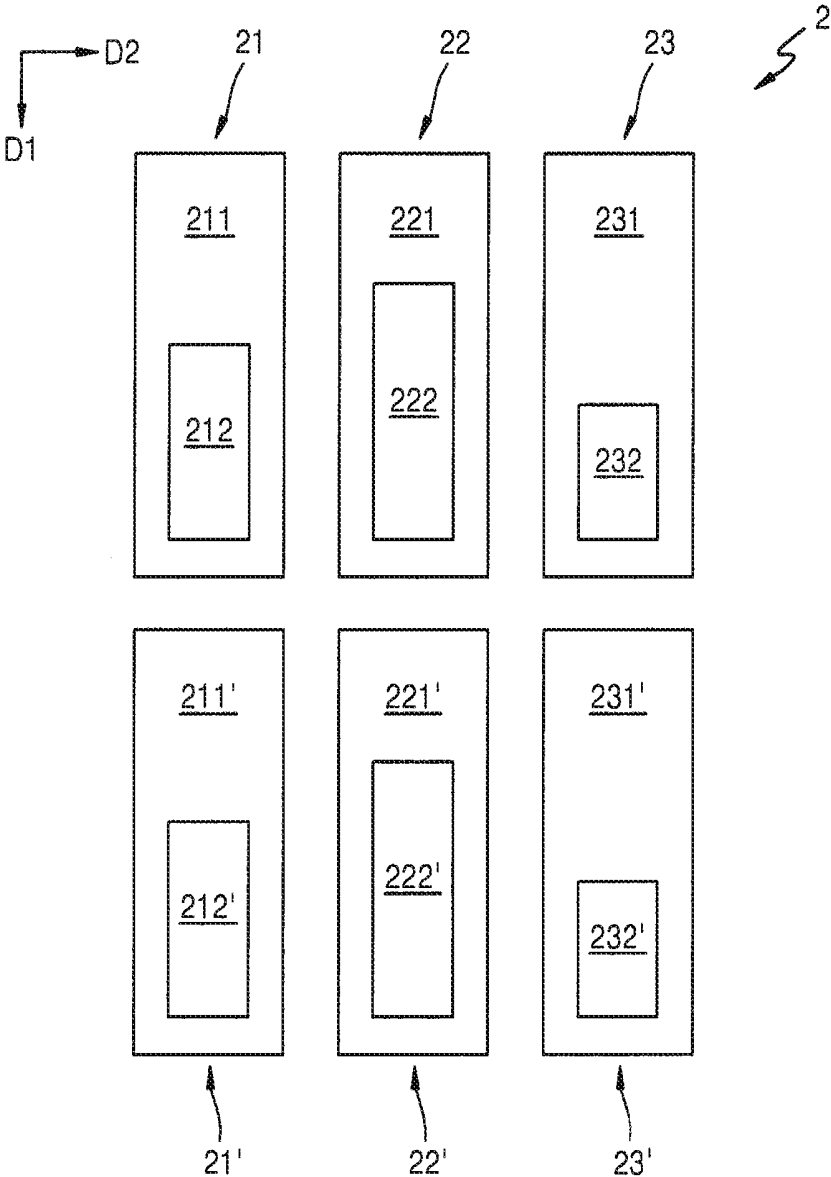

FIG. 10

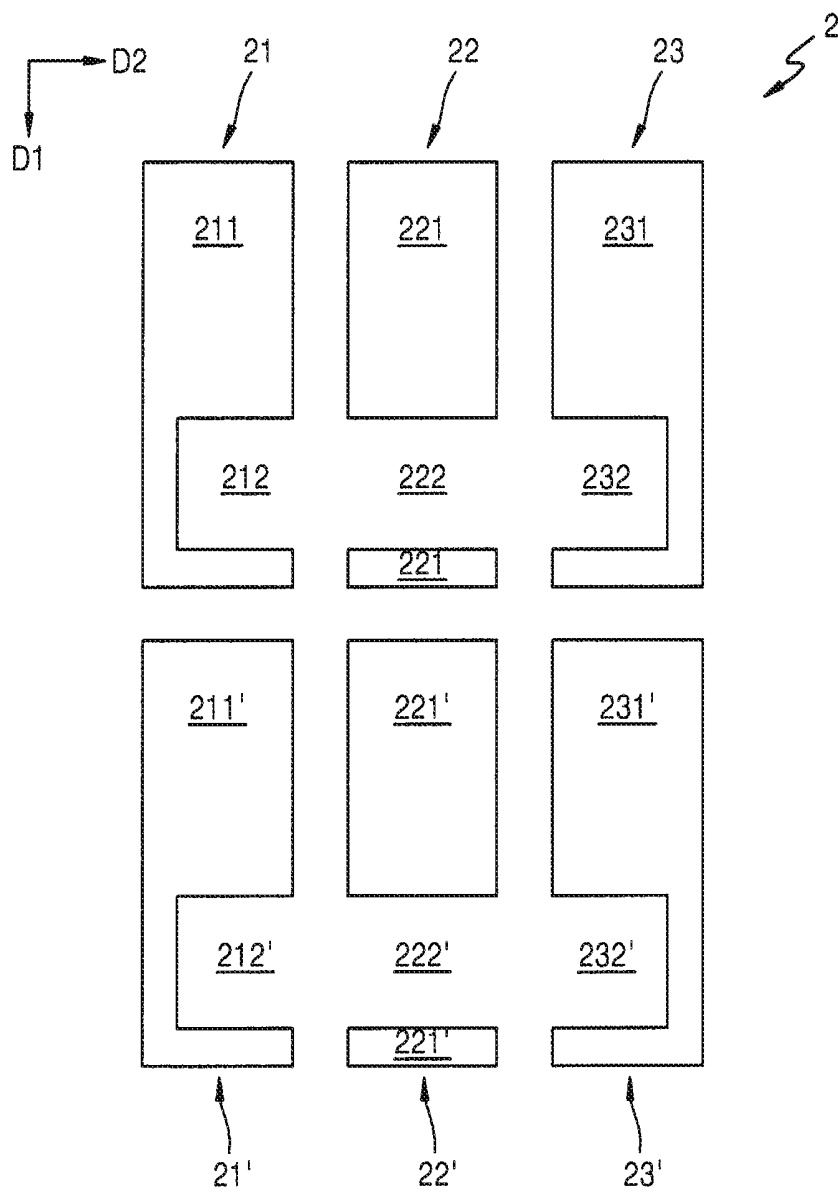

FIG. 11

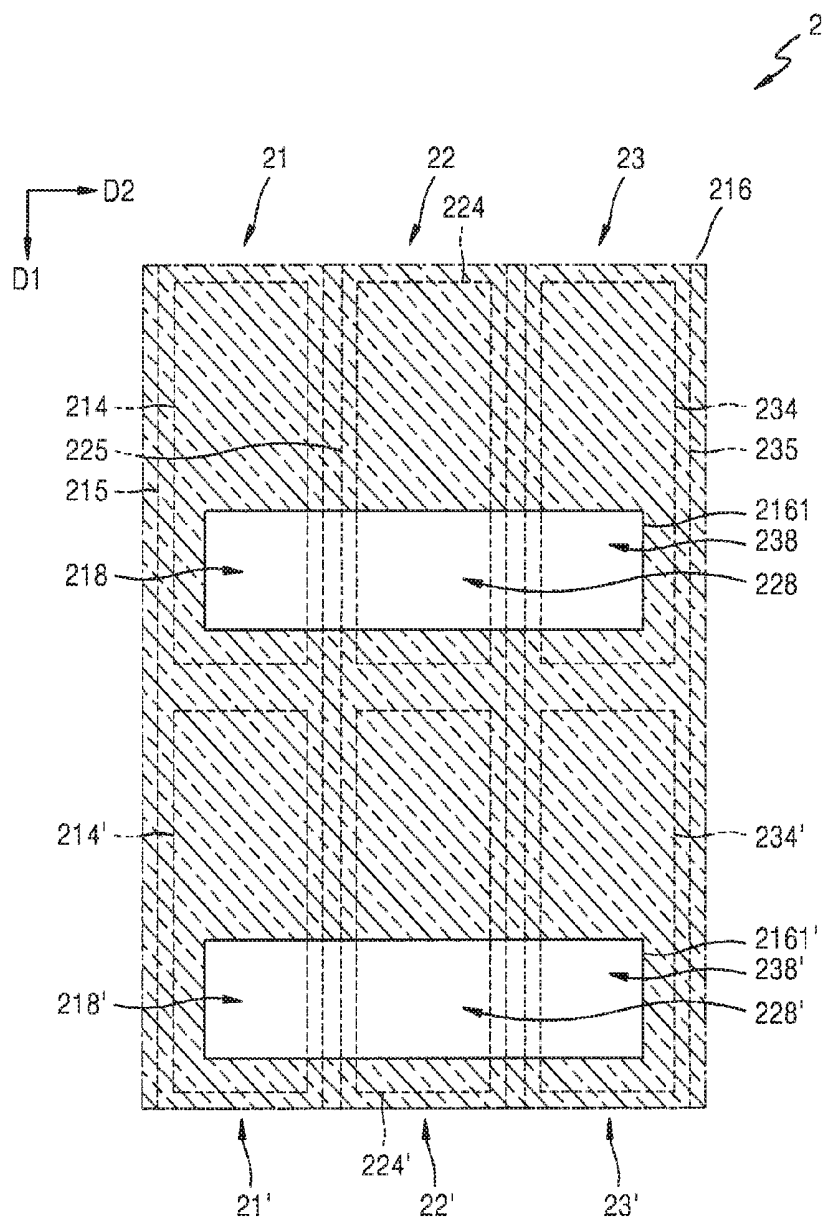

FIG. 12

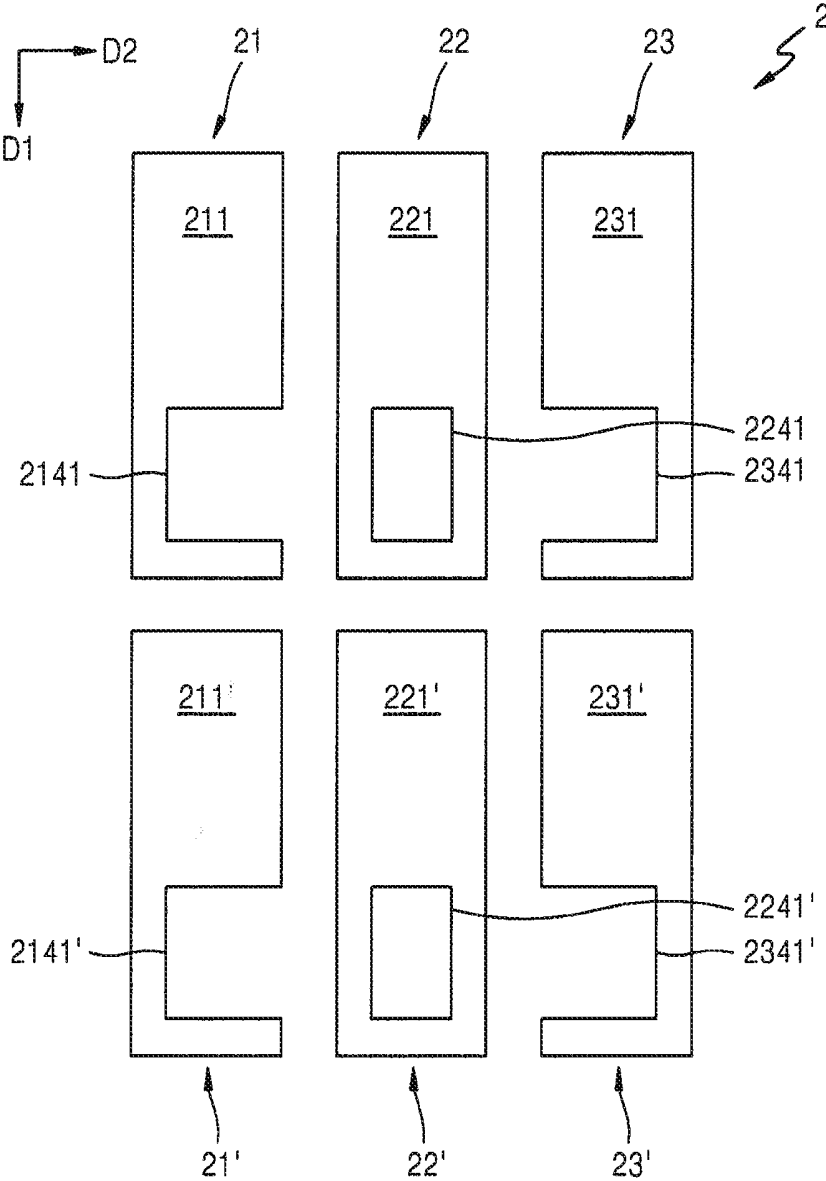

FIG. 13

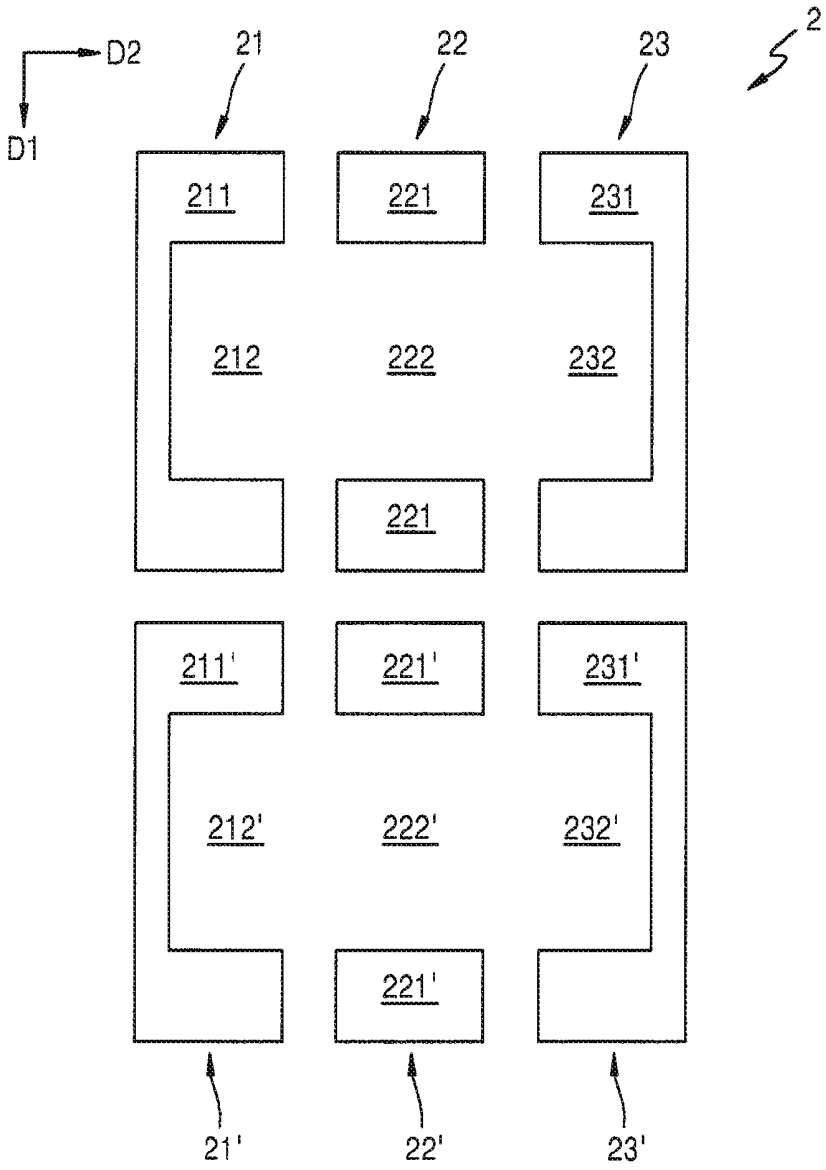

FIG. 14

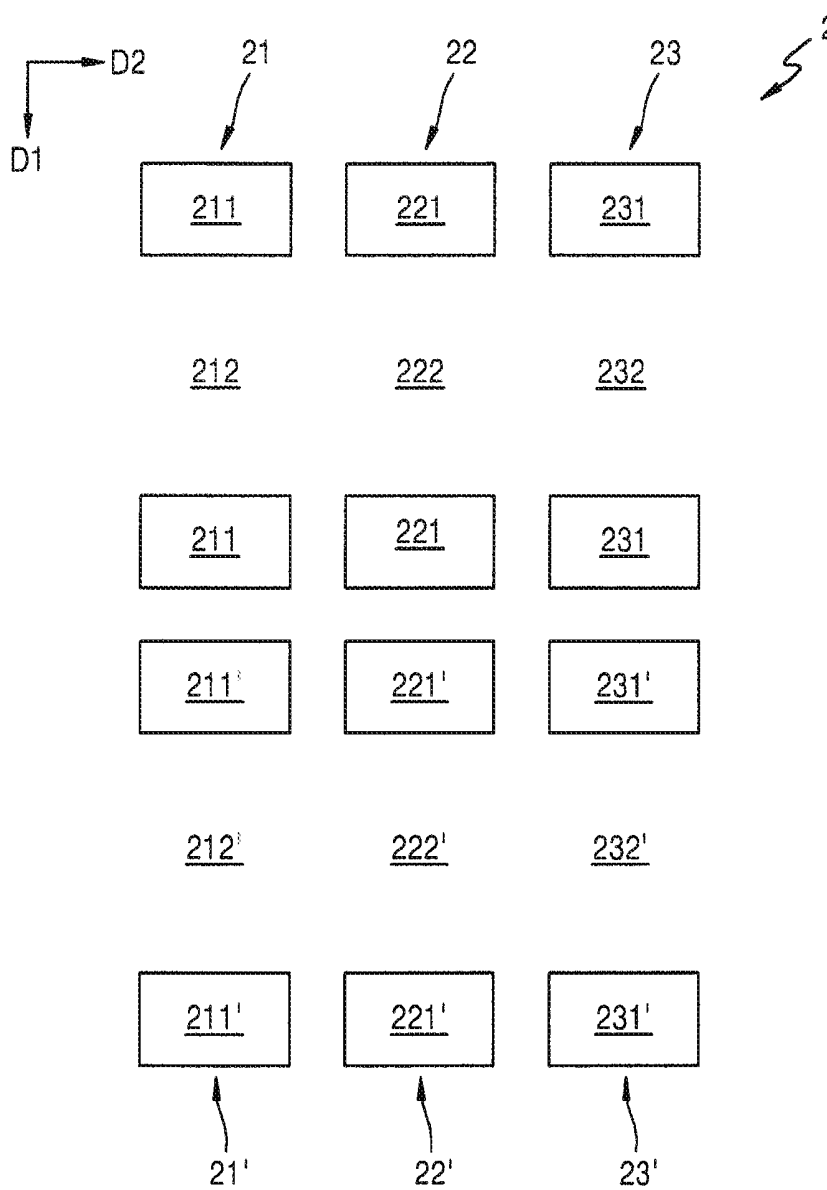
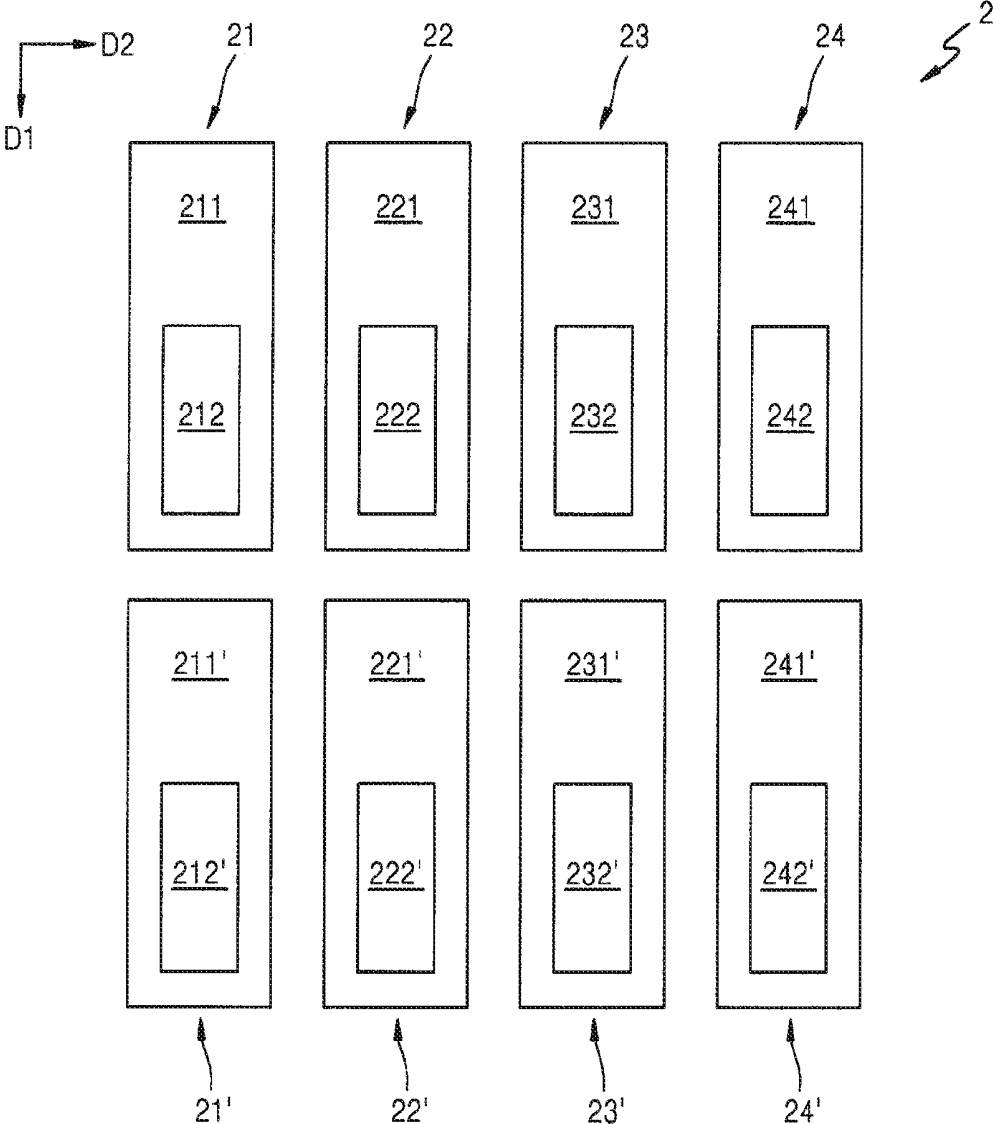

FIG. 15



## ORGANIC LIGHT EMITTING DISPLAY DEVICE

### CROSS-REFERENCE TO RELATED APPLICATION

**[0001]** This application claims priority to and the benefit of Korean Patent Application No. 10-2013-0014971, filed on Feb. 12, 2013 in the Korean Intellectual Property Office, the disclosure of which is incorporated herein in its entirety by reference.

### BACKGROUND

**[0002]** 1. Field

**[0003]** The following description relates to an organic light emitting display device.

**[0004]** 2. Description of the Related Art

**[0005]** Organic light emitting display devices are being widely applied to personal portable devices, such as MP3 players and mobile phones, and to TVs due to characteristics such as wide viewing angle, high contrast, fast response speed, and low power consumption.

**[0006]** An organic light emitting display device is self-emissive, and thus, an additional light source is not necessary, unlike in a liquid crystal display (LCD) device. Also, a thickness and a weight of the organic light emitting display device may be less than that of an LCD device.

**[0007]** Also, an organic light emitting display device may be formed as a transparent display device by including transparent thin film transistors (TFTs) or organic light emitting diodes therein.

### SUMMARY

**[0008]** Aspects of embodiments of the present invention are directed toward a transparent organic light emitting display device having improved transmittance and capable of displaying an image that appears continuous.

**[0009]** According to an embodiment of the present invention, there is provided an organic light emitting display device including: a plurality of first sub-pixels arranged adjacent to each other along a first direction, each of the plurality of first sub-pixels includes a first emission region emitting configured to emit light of a first color and a first transmission region configured to transmit external light (e.g., without emitting light), wherein the first emission regions of at least two of the plurality of first sub-pixels are adjacent to each other; and a plurality of second sub-pixels arranged adjacent to each other along the first direction and adjacent to corresponding ones of the plurality of first sub-pixels along a second direction crossing the first direction, each of the plurality of second sub-pixels includes a second emission region configured to emit light of a second color different from the first color and a second transmission region configured to transmit external light, wherein the second emission regions of at least two of the plurality of second sub-pixels are adjacent to each other.

**[0010]** The first transmission region of one of the plurality of first sub-pixels and the second transmission region of a corresponding one of the plurality of second sub-pixels may be adjacent to and separated from each other along the second direction.

**[0011]** At least one of the first and second transmission regions may be an island.

**[0012]** The first transmission region of one of the plurality of first sub-pixels and the second transmission region of a

corresponding one of the plurality of second sub-pixels may be adjacent and connected to each other along the second direction.

**[0013]** The first emission region of one first sub-pixel may be divided by the corresponding first transmission region.

**[0014]** The second emission region of one second sub-pixel may be divided by the corresponding second transmission region.

**[0015]** The first transmission region and the second transmission region may have areas that are different from each other.

**[0016]** Either the first or second sub-pixel having a light emission efficiency greater than that of the other sub-pixel may have a transmission region that is larger than the transmission region of the other sub-pixel.

**[0017]** The first emission region and the second emission region may have shapes that are different from each other.

**[0018]** The first transmission region and the second transmission region may have shapes that are different from each other.

**[0019]** According to another embodiment of the present invention, there is provided an organic light emitting display device including: a plurality of first pixel circuit units; a plurality of 1-1 electrodes adjacent to and separated from each other along a first direction, each of the plurality of 1-1 electrodes are electrically coupled to a corresponding one of the plurality of first pixel circuit units; a first emission layer on the plurality of 1-1 electrodes, the first emission layer configured to emit light of a first color; a plurality of second pixel circuit units; a plurality of 2-1 electrodes adjacent to and separated from each other along the first direction and adjacent to corresponding ones of the plurality of 1-1 electrodes along a second direction crossing the first direction, each of the plurality of 2-1 electrodes are electrically coupled to corresponding ones of the plurality of second pixel circuit units; a second emission layer on the plurality of 2-1 electrodes, the second emission layer configured to emit light of a second color that is different from the first color; and a second electrode on the first and second emission layers, the second electrode includes a plurality of first transmission units, each at a portion of a corresponding one of the plurality of 1-1 electrodes and configured to transmit external light (e.g., without emitting light), and a plurality of second transmission units, each at a portion of a corresponding one of the plurality of 2-1 electrodes and configured to transmit external light (e.g., without emitting light).

**[0020]** Ones of the plurality of first transmission unit and corresponding ones of the plurality of second transmission units may be adjacent to and separated from each other along the second.

**[0021]** At least one of the first and second transmission units may be an island.

**[0022]** One of the plurality of first transmission units and a corresponding one of the plurality of second transmission units may be adjacent and connected to each other along the second direction.

**[0023]** Ones of the plurality of first transmission units may be at an edge portion nearest an adjacent one of the plurality of second transmission units of each of the plurality of 1-1 electrodes.

**[0024]** Ones of the plurality of second transmission units may be at an edge portion nearest an adjacent one of the plurality of first transmission units of each of the plurality of 2-1 electrodes.

[0025] The first transmission units and the second transmission units may have areas that are different from each other.

[0026] The first or second emission layer having a light emission efficiency greater than that of the other emission layer may have a corresponding transmission unit having an area that is larger than that of the transmission unit corresponding to the other emission layer.

[0027] The first transmission units and the second transmission units may have shapes that are different from each other.

#### BRIEF DESCRIPTION OF THE DRAWINGS

[0028] The above and other features and aspects of embodiments of the present invention will become more apparent by describing, in detail, embodiments thereof with reference to the attached drawings in which:

[0029] FIG. 1 is a cross-sectional view of an organic light emitting display device according to an embodiment of the present invention;

[0030] FIG. 2 is a cross-sectional view of an organic light emitting display device according to another embodiment of the present invention;

[0031] FIG. 3 is a plan view of a part of the organic emission unit shown in FIG. 1 and FIG. 2 in detail;

[0032] FIG. 4 is a plan view of the organic emission unit of FIG. 3 in more detail;

[0033] FIG. 5 is a cross-sectional view of the organic emission unit taken along the line V-V of FIG. 4;

[0034] FIG. 6 is a plan view showing a part of an organic emission unit according to another embodiment of the present invention;

[0035] FIG. 7 is a partially cross-sectional view of a first sub-pixel according to an embodiment of the present invention;

[0036] FIG. 8 is a plan view of a part of an organic emission unit according to another embodiment of the present invention;

[0037] FIG. 9 is a plan view of a part of an organic emission unit according to another embodiment of the present invention;

[0038] FIG. 10 is a plan view of a part of an organic emission unit according to another embodiment of the present invention;

[0039] FIG. 11 is a partial plan view of the organic emission unit of FIG. 10;

[0040] FIG. 12 is a plan view of a part of an organic emission unit according to another embodiment of the present invention;

[0041] FIG. 13 is a plan view of a part of an organic emission unit according to another embodiment of the present invention;

[0042] FIG. 14 is a plan view of a part of an organic emission unit according to another embodiment of the present invention; and

[0043] FIG. 15 is a plan view of a part of an organic emission unit according to another embodiment of the present invention.

#### DETAILED DESCRIPTION

[0044] Hereinafter, embodiments of the present invention will be described in detail with reference to accompanying drawings. As used herein, the term "and/or" includes any and all combinations of one or more of the associated listed items. Expressions such as "at least one of," when preceding a list of

elements, modify the entire list of elements and do not modify the individual elements of the list.

[0045] FIGS. 1 and 2 are cross-sectional views of organic light emitting display devices according to embodiments of the present invention.

[0046] Referring to FIG. 1, an organic light emitting display device according to an embodiment of the present invention includes an organic emission unit 2 formed on a surface of a substrate 1 and a sealing unit 3 for sealing the organic emission unit 2.

[0047] According to the embodiment, the sealing unit 3 may include a sealing substrate 31. The sealing substrate 31 may be a transparent glass substrate or a transparent plastic substrate so as to transmit images (e.g., transmit light) from the organic emission unit 2 and to prevent external air and/or moisture from infiltrating into the organic emission unit 2.

[0048] Edges of the substrate 1 and the sealing substrate 31 (e.g., an area including the periphery of the substrate 1 and the sealing substrate 31) are coupled to each other by a sealing material 32 so that a space 33 between the substrate 1 and the sealing substrate 31 may be sealed. A moisture absorbent and/or a filling material may be located in the space 33.

[0049] As shown in FIG. 2, instead of using the sealing substrate 31, a thin sealing film 34 may be formed on or over the organic emission unit 2 to protect and seal the organic emission unit 2 against external air and/or moisture. The sealing film 34 may have a structure, for example, in which a layer formed of an inorganic material, such as silicon oxide or silicon nitride, and a layer formed of an organic material, such as epoxy or polyimide, are alternately formed (e.g., stacked). However, the present invention is not limited thereto, and a sealing structure such as a transparent thin film may be used as the sealing film 34.

[0050] The organic light emitting display devices according to the embodiments shown in FIGS. 1 and 2 may be bottom-emission display devices that display images toward the substrate 1 (e.g., display images from the organic emission unit 2 toward the substrate 1), top-emission display devices that display images toward the sealing substrate 31 or the sealing film 34 (e.g., display images from the organic emission unit 2 toward the sealing substrate 31 or the sealing film 34), or dual-emission display devices that display images toward both the substrate 1 and the sealing substrate 31 or both the substrate 1 and the sealing film 34 (e.g., display images from the organic emission unit 2 toward the substrate 1 and either the sealing substrate 31 or the sealing film 34).

[0051] Such organic light emitting display devices include a light emission region and a light transmission region so as to form a transparent and/or see-through display device.

[0052] However, sub-pixels arranged along lines and emitting light of the same color may appear disconnected (e.g., separated) due to the transmission regions therebetween, thereby reducing a resolution of the display device.

[0053] According to embodiments of the present invention, the disconnected appearance of the display device occurring between emission regions of sub-pixels arranged in a line and other sub-pixels arranged in a next line (e.g., an adjacent line) may be addressed by making the emission regions of the sub-pixels of the line and the sub-pixels of the next line (e.g., adjacent line) appear as if they are connected to each other.

[0054] FIG. 3 is a plan view of a part of the organic emission unit 2 shown in FIGS. 1 and 2 in more detail.

[0055] Referring to FIG. 3, first sub-pixels 21 and 21' emit light of a first color and are disposed (e.g., located or

arranged) along a first direction D1 to form a column line. In addition, second sub-pixels **22** and **22'** emit light of a second color and are disposed adjacent to the first sub-pixels **21** and **21'**, respectively, along a second direction D2 which crosses (e.g., is substantially perpendicular to) the first direction D1. The second sub-pixels **22** and **22'** are arranged along the first direction D1 to form another column line (e.g., an adjacent column line). Third sub-pixels **23** and **23'** emit light of a third color and are disposed adjacent to the second sub-pixels **22** and **22'**, respectively, along the second direction D2. The third sub-pixels **23** and **23'** are arranged along the first direction D1 to form yet another column line. The first color may be red, the second color may be green, and the third color may be blue.

[0056] The first sub-pixels **21** and **21'** respectively include first emission regions **211** and **211'** and first transmission regions **212** and **212'**, wherein the first color light may be emitted by the first emission regions **211** and **211'** and external light may be transmitted (e.g., without emitting light) through the first transmission regions **212** and **212'**.

[0057] The second sub-pixels **22** and **22'** respectively include second emission regions **221** and **221'** and second transmission regions **222** and **222'**, wherein the second color light is different from the first color light and may be emitted by the second emission regions **221** and **221'** and external light may be transmitted (e.g., without emitting light) through the second transmission regions **222** and **222'**.

[0058] The third sub-pixels **23** and **23'** respectively include third emission regions **231** and **231'** and third transmission regions **232** and **232'**, wherein the third color light is different from the first and second color lights and may be emitted by the third emission regions **231** and **231'** and external light may be transmitted (e.g., without emitting light) through the third transmission regions **232** and **232'**.

[0059] The first emission region **211** of one first sub-pixel **21** and the first emission region **211'** of another first sub-pixel **21'**, the another first sub-pixel **21'** being adjacent to the first sub-pixel **21** along the first direction D1, are adjacent to each other.

[0060] The first transmission regions **212** and **212'** are formed as islands in the first emission regions **211** and **211'**, respectively. That is, the first transmission regions **212** and **212'** are surrounded by (e.g., surrounded along a periphery thereof by) the first emission regions **211** and **211'**, respectively.

[0061] The second emission region **221** of one second sub-pixel **22** and the second emission region **221'** of another second sub-pixel **22'**, the another second sub-pixel **22'** being adjacent to the second sub-pixel **22** along the first direction D1, are adjacent to each other.

[0062] The second transmission regions **222** and **222'** are formed as islands in the second emission regions **221** and **221'**, respectively. That is, the second transmission regions **222** and **222'** are surrounded by (e.g., surrounded along a periphery thereof by) the second emission regions **221** or **221'**, respectively.

[0063] The third emission region **231** of one first sub-pixel **23** and the third emission region **231'** of another third sub-pixel **23'**, the another third sub-pixel **23'** being adjacent to the third sub-pixel **23** along the first direction D1, are adjacent to each other.

[0064] The third transmission regions **232** and **232'** are formed as islands in the third emission regions **231** and **231'**, respectively. That is, the third transmission regions **232** and

**232'** are surrounded by (e.g., surrounded along a periphery thereof by) the third emission regions **231** and **231'**, respectively.

[0065] Accordingly, the first sub-pixels **21** and **21'** in the column line may appear as if they are connected to each other. Likewise, the second sub-pixels **22** and **22'** and the third sub-pixels **23** and **23'** may appear as if they are each connected to the corresponding other sub-pixel.

[0066] In addition, the transmission regions of the first sub-pixels **21** and **21'** and second sub-pixels **22** and **22'**, and the transmission regions of the second sub-pixels **22** and **22'** and the third sub-pixels **23** and **23'** are disconnected, and thus, their respective transmitted external light may be represented softly. That is, as shown in FIG. 3, the first transmission regions **212** and **212'** and the second transmission regions **222** and **222'**, and the second transmission regions **222** and **222'** and the third transmission regions **232** and **232'**, which are adjacent to each other along the second direction D2, are separated from each other so that the transmission regions may not appear as lines (e.g., continuous lines) extending along the second direction D2 and the disconnected appearance of the color display (e.g., of the emission regions) may be reduced or prevented.

[0067] FIG. 4 is a diagram showing the organic emission unit **2** of FIG. 3 in more detail, and FIG. 5 is a cross-sectional view of the organic emission unit **2** taken along the line V-V of FIG. 4.

[0068] First pixel circuit units **213** and **213'** are respectively disposed (e.g., located) in the first sub-pixels **21** and **21'**. Each of the first pixel circuit units **213** and **213'** may include a thin film transistor T as shown in FIG. 5.

[0069] As shown in FIG. 5, a buffer layer **111** is formed on a surface of the substrate **1**, and the thin film transistor T is formed on the buffer layer **111**.

[0070] A semiconductor active layer **2131** is formed on the buffer layer **111**.

[0071] The buffer layer **111** prevents impurities (e.g., impurity atoms) from infiltrating while the surface of the substrate **1** is planarized and may be formed of various materials capable of performing the above function. For example, the buffer layer **111** may be formed of an inorganic material, such as silicon oxide, silicon nitride, silicon oxynitride, aluminium oxide, aluminium nitride, titanium oxide, or titanium nitride, an organic material, such as polyimide, polyester, or acryl, or a stacked structure thereof. The buffer layer **111** may be omitted if necessary or desired.

[0072] The semiconductor active layer **2131** may be formed of polycrystalline silicon; however, the present invention is not limited thereto. That is, the semiconductor active layer **2131** may be formed of oxide semiconductor. For example, the semiconductor active layer **2131** may be a G-I-Z-O layer [(In<sub>2</sub>O<sub>3</sub>)<sub>a</sub>(Ga<sub>2</sub>O<sub>3</sub>)<sub>b</sub>(ZnO)<sub>c</sub> layer] (where a, b, and c are real numbers satisfying conditions a≥0, b≥0, and c>0).

[0073] A gate insulating layer **112** is formed on the buffer layer **111** so as to cover or substantially cover the semiconductor active layer **2131**, and a gate electrode **2132** is formed on the gate insulating layer **112**.

[0074] An inter-insulating layer **113** is formed on the gate insulating layer **112** so as to cover or substantially cover the gate electrode **2132**. A source electrode **2133** and a drain electrode **2134** are formed on the inter-insulating layer **113** and each contact the semiconductor active layer **2131** via corresponding contact holes.

[0075] The thin film transistor T is not limited to the above structure, and various structures of the thin film transistor T may be applied.

[0076] As shown in FIG. 4, second pixel circuit units 223 and 223' are disposed (e.g., located) in the second sub-pixels 22 and 22', respectively, and third pixel circuit units 233 and 233' are disposed in the third sub-pixels 23 and 23', respectively. Each of the second pixel circuit units 223 and 223' and each of the third pixel circuit units 233 and 233' may include the thin film transistor T shown in FIG. 5.

[0077] As shown in FIG. 5, a passivation layer 114 is formed on the inter-insulating layer 113 so as to cover or substantially cover the thin film transistor T, and a 1-1 electrode 214 is formed on the passivation layer 114. The 1-1 electrode 214 may contact the drain electrode 2134 of the thin film transistor T via a hole (e.g., a through hole) formed in the passivation layer 114.

[0078] A pixel defining layer 115 is formed on the passivation layer 114 so as to cover edges of the 1-1 electrode 214 (e.g., the pixel defining layer 115 is formed on the passivation layer 114 and along the periphery of the 1-1 electrode 214).

[0079] As shown in FIG. 4, 1-1 electrodes 214 and 214' are separated from each other and are respectively located in the first sub-pixels 21 and 21'. The 1-1 electrodes 214 and 214' are electrically coupled to (e.g., electrically connected to) the first pixel circuit units 213 and 213', respectively. In FIG. 4, the 1-1 electrodes 214 and 214' overlap the first pixel circuit units 213 and 213' (e.g., cover the first pixel circuit units 213 and 213'), respectively; however, the present invention is not limited thereto. That is, the 1-1 electrodes 214 and 214' may be located so as not to overlap or cover the first pixel circuit units 213 and 213'.

[0080] 2-1 electrodes 224 and 224' are separated from each other and are located in the second sub-pixels 22 and 22', respectively. The 2-1 electrodes 224 and 224' are electrically coupled to (e.g., electrically connected to) the second pixel circuit units 223 and 223', respectively. In FIG. 4, the 2-1 electrodes 224 and 224' overlap the second pixel circuit units 223 and 223' (e.g., cover the second pixel circuit units 223 and 223'), respectively; however, the present invention is not limited thereto. That is, the 2-1 electrodes 224 and 224' may be located so as not to overlap or cover the second pixel circuit units 223 and 223'.

[0081] 3-1 electrodes 234 and 234' are separated from each other and are located in the third sub-pixels 23 and 23', respectively. The 3-1 electrodes 234 and 234' are electrically coupled to (e.g., electrically connected to) the third pixel circuit units 233 and 233', respectively. In FIG. 4, the 3-1 electrodes 234 and 234' overlap the third pixel circuit units 233 and 233' (e.g., cover the third pixel circuit units 233 and 233'), respectively; however, the present invention is not limited thereto. That is, the 3-1 electrodes 234 and 234' may be located so as not to overlap or cover the third pixel circuit units 233 and 233'.

[0082] The 1-1 electrodes 214 and 214' may be shaped as rectangles, longer sides of which extend along the first direction D1, as shown in FIG. 4. Likewise, the 2-1 electrodes 224 and 224' and the 3-1 electrodes 234 and 234' may have shapes similar to those of the 1-1 electrodes 214 and 214'.

[0083] A first emission layer 215 is formed on (e.g., formed over) the 1-1 electrodes 214 and 214'. Referring to FIG. 4, the first emission layer 215 may be formed as a line (e.g., a continuous line) extending along the first direction D1. However, the present invention is not limited thereto; that is, the

first emission layer 215 may be patterned or formed to cover the 1-1 electrodes 214 and 214'.

[0084] A second emission layer 225 is formed on (e.g., formed over) the 2-1 electrodes 224 and 224'. Referring to FIG. 4, the second emission layer 225 may be formed as a line (e.g., a continuous line) extending along the first direction D1. However, the present invention is not limited thereto; that is, the second emission layer 225 may be patterned or formed to cover the 2-1 electrodes 224 and 224'.

[0085] A third emission layer 235 is formed on (e.g., formed over) the 3-1 electrodes 234 and 234'. Referring to FIG. 4, the third emission layer 235 may be formed as a line (e.g., a continuous line) extending along the first direction D1. However, the present invention is not limited thereto; that is, the third emission layer 235 may be patterned or formed to cover the 3-1 electrodes 234 and 234'.

[0086] A second electrode 216 is formed to substantially cover the first emission layer 215, the second emission layer 225, and the third emission layer 235. The second electrode 216 is an electrode to which a common voltage is applied and is formed to substantially cover all the sub-pixels of the organic emission unit 2.

[0087] The 1-1 electrodes 214 and 214', the 2-1 electrodes 224 and 224', and the 3-1 electrodes 234 and 234' may be anode electrodes, and the second electrode 216 may be a cathode electrode. However, polarities of the above-described electrodes may be opposite than in the above example.

[0088] The first emission layer 215, the second emission layer 225, and the third emission layer 235 may be organic emission layers including an organic emission material emitting red light, an organic emission material emitting green light, and organic emission material emitting blue light, respectively. Although not shown in FIGS. 4 and 5, at least one or more organic layers including a hole injection transport layer and/or an electron injection transport layer may be further disposed (e.g., located) between each of the 1-1 electrodes 214 and 214', the 2-1 electrodes 224 and 224', and the 3-1 electrodes 234 and 234' and the second electrode 216. When the 1-1 electrodes 214 and 214', the 2-1 electrodes 224 and 224', and the 3-1 electrodes 234 and 234' are anode electrodes and the second electrode 216 is a cathode electrode, an organic layer including the hole injection transport layer injection and/or transporting holes may be disposed between each of the first emission layer 215, the second emission layer 225, and the third emission layer 235 and of the 1-1 electrodes 214 and 214', the 2-1 electrodes 224 and 224', and the 3-1 electrodes 234 and 234', respectively. Also, an organic layer including an electron injection transport layer for injecting and/or transporting electrons may be disposed between each of the first emission layer 215, the second emission layer 225, and the third emission layer 235 and the second electrode 216. The hole injection transport layer and the electron injection transport layer are common layers that may cover all the sub-pixels of the organic emission unit 2.

[0089] Organic layers including the first emission layer 215, the second emission layer 225, and the third emission layer 235 may be formed in various ways, such as by vacuum deposition, printing, and/or laser thermal transport.

[0090] The buffer layer 111, the gate insulating layer 112, the inter-insulating layer 113, the passivation layer 114, and/or the pixel defining layer 115 may be formed as insulating layers having high transmittance.

[0091] The 1-1 electrodes **214** and **214'**, the 2-1 electrodes **224** and **224'**, and the 3-1 electrodes **234** and **234'** may be formed as transparent electrodes, semi-transparent electrodes, or reflective electrodes, and may include, for example, indium tin oxide (ITO), indium zinc oxide (IZO), zinc oxide (ZnO), or indium oxide (In<sub>2</sub>O<sub>3</sub>).

[0092] The second electrode **216** may be formed as a transparent electrode, a semi-transparent electrode, or a reflective electrode, and may include silver (Ag), magnesium (Mg), aluminium (Al), platinum (Pt), palladium (Pd), gold (Au), nickel (Ni), neodymium (Nd), iridium (Ir), chromium (Cr), lithium (Li), calcium (Ca), Ytterbium (Yb), or a compound thereof.

[0093] As shown in FIGS. **4** and **5**, if the 1-1 electrodes **214** and **214'**, the 2-1 electrodes **224** and **224'**, and the 3-1 electrodes **234** and **234'** are formed in the transparent regions (e.g., transmission regions), they may be formed as transparent electrodes.

[0094] As shown in FIGS. **4** and **5**, the second electrode **216** includes a transmission window formed as an opening to form a transmission unit.

[0095] That is, first transmission windows **217** and **217'** of the second electrode **216** transmit external light at locations corresponding to center portions of the 1-1 electrodes **214** and **214'** and are formed as openings to form first transmission units **218** and **218'**. Second transmission windows **227** and **227'** of the second electrode **216** transmit external light at locations corresponding to center portions of the 2-1 electrodes **224** and **224'** and are formed as openings to form second transmission units **228** and **228'**. Third transmission windows **237** and **237'** of the second electrode **216** transmit external light at locations corresponding to center portions of the 3-1 electrodes **234** and **234'** and are formed as openings to form second transmission units **238** and **238'**. In the present embodiment, the center portion is any portion except for end portions in the first direction D1 of any of the 1-1 electrodes **214** and **214'**, the 2-1 electrodes **224** and **224'**, and the 3-1 electrodes **234** and **234'**, and is not limited to a location in the direct or exact center of the 1-1 electrodes **214** and **214'**, the 2-1 electrodes **224** and **224'**, and the 3-1 electrodes **234** and **234'** in either the first or second directions D1 and D2. That is, the first transmission units **218** and **218'** are not formed on portions corresponding to at least one edge of the 1-1 electrodes **214** and **214'**. In addition, the second transmission units **228** and **228'** are not formed on portions corresponding to at least one edge of the 2-1 electrodes **224** and **224'**, and the third transmission units **238** and **238'** are not formed on portions corresponding to at least one edge of the 3-1 electrodes **234** and **234'**. Accordingly, the appearance of a disconnected display of the emission region due to the transmission units may be reduced.

[0096] As described above, because the first transmission units **218** and **218'**, the second transmission units **228** and **228'**, and the third transmission units **238** and **238'** are formed in the second electrode **216** that includes the metal having a low transmittance and high reflectivity, the external light transmittance of the first transmission regions **212** and **212'**, the second transmission regions **222** and **222'**, and the third transmission regions **232** and **232'** of the sub-pixels of the organic emission unit **2** shown in FIG. **3** may be high, and the light emission regions of adjacent sub-pixels along the first direction D1 may not appear as if they are disconnected.

[0097] In the embodiment shown in FIG. **5**, because the first emission layer **215** and the 1-1 electrode **214** are located in the

first transmission region **212**, the 1-1 electrode **214** may be formed as a transparent electrode. Because the first emission layer **215** is formed of a material that has high transmittance when a power is not applied thereto, the external light transmittance of the first transmission region **212** may be high.

[0098] FIG. **6** is a partial plan view of an organic emission unit according to another embodiment of the present invention. FIG. **6** shows another embodiment of the 1-1 electrodes **214** and **214'**, the 2-1 electrodes **224** and **224'**, and the 3-1 electrodes **234** and **234'**. The 1-1 openings **2141** and **2141'**, 2-1 openings **2241** and **2241'**, and 3-1 openings **2341** and **2341'** may be formed on regions substantially corresponding to the first transmission regions **212** and **212'**, the second transmission regions **222** and **222'**, and the third transmission regions **232** and **232'** of the 1-1 electrodes **214** and **214'**, the 2-1 electrodes **224** and **224'**, and the 3-1 electrodes **234** and **234'**, respectively, as shown in FIG. **3**. Accordingly, even when the 1-1 electrodes **214** and **214'**, the 2-1 electrodes **224** and **224'**, and the third electrodes **234** and **234'** are formed as reflective electrodes, the external light transmittance of the first transmission regions **212** and **212'**, the second transmission regions **222** and **222'**, and the third transmission regions **232** and **232'** may not be reduced.

[0099] FIG. **7** is a cross-sectional view of the first sub-pixel **21** according to another embodiment of the present invention. In FIG. **7**, the 1-1 opening **2141** is formed in the 1-1 electrode **214**, and a second opening **1141** is formed in the passivation layer **114**. The 1-1 opening **2141** and the second opening **1141** are formed in the region corresponding to the first transmission region **212**. According to the embodiment shown in FIG. **7**, the second opening **1141** is formed in or through the passivation layer **114**, and thus, the external light transmittance of the first transmission region **212** may be further increased. Although FIG. **7** only shows the first sub-pixel **21**, the embodiment shown in FIG. **7** may be similarly applied to each of the second and third sub-pixels.

[0100] Referring to FIG. **7**, the first emission layer **215** is in the first transmission region **212** (e.g., an opening is not formed in the first emission layer **215** at a portion corresponding to the first transmission region **212**); however, the present invention is not limited thereto. That is, the first emission layer **215** may have an opening at the portion corresponding to the first transmission region **212**.

[0101] Also, according to the embodiment shown in FIG. **7**, the second opening **1141** is formed only in or through the passivation layer **114**; however, the present invention is not limited thereto. That is, the second opening may be formed in the interlayer dielectric **113**, the gate insulating layer **112**, and/or the buffer layer **111** at a portion corresponding to the first transmission region **212**.

[0102] FIG. **8** is a partial plan view of another embodiment of the organic emission unit **2** in more detail.

[0103] Referring to FIG. **8**, the first transmission regions **212** and **212'** are located at center portions of the first sub-pixels **21** and **21'** along the first direction D1, unlike the embodiment shown in FIG. **3**. In addition, the second transmission regions **222** and **222'** are located at center portions of the second sub-pixels **22** and **22'**, respectively, along the first direction D1, and the third transmission regions **232** and **232'** are located at center portions of the third sub-pixels **23** and **23'**, respectively, along the first direction D1. Accordingly, the first sub-pixels **21** and **21'** may not appear as if they are disconnected from each other along the first direction D1. The appearance of the second and third sub-pixels **22**, **22'**, **23**, and

23' being disconnected from each other along the first direction D1 may also be reduced or prevented.

[0104] FIG. 8 is a schematic plan view of the first sub-pixels 21 and 21', the second sub-pixels 22 and 22', and the third sub-pixels 23 and 23'; however, detailed structures shown in FIGS. 4 through 7 may be applied thereto.

[0105] FIG. 9 is a partial plan view of the organic emission unit 2 according to another embodiment in more detail.

[0106] Referring to FIG. 9, the first transmission regions 212 and 212', the second transmission regions 222 and 222', and the third transmission regions 232 and 232' have different sizes from each other, unlike the embodiment shown in FIG. 3. The sizes of the first transmission regions 212 and 212', the second transmission regions 222 and 222', and the third transmission regions 232 and 232' may be determined according to differences between light emitting efficiencies of the first emission regions 211 and 211', the second emission regions 221 and 221', and the third emission regions 231 and 231', respectively. That is, the size of the transmission region of the sub-pixel having the emission region which has a greater emission efficiency is increased (e.g., is larger compared with the transmission regions of the other sub-pixels), and the size of the transmission region of the sub-pixel having the emission region which has a lower emission efficiency is reduced. The light emission efficiencies of the emission regions may be determined by (e.g., according to) emission efficiencies of the light emission layers of the sub-pixels.

[0107] Accordingly, the size of the transmission region is reduced in the sub-pixel having a lower light emission efficiency, thereby preventing further reduction of the light emission efficiency. Also, light emission efficiencies of pixels, each including sub-pixels emitting light of different colors, may be maintained (e.g., constantly maintained).

[0108] FIG. 9 is a schematic plan view showing the first sub-pixels 21 and 21', the second sub-pixels 22 and 22', and the third sub-pixels 23 and 23'; however, detailed structures shown in FIGS. 4 through 7 may be applied to the structure of FIG. 9.

[0109] FIG. 10 is a partial plan view of the organic emission unit 2 according to another embodiment of the present invention.

[0110] Referring to FIG. 10, the first transmission regions 212 and 212', the second transmission regions 222 and 222', and the third transmission regions 232 and 232' are formed to have different shapes from each other, unlike the embodiment shown in FIG. 3. The second transmission regions 222 and 222' are formed as squares at a center portion along the second direction D2 of the second sub-pixels 22 and 22', respectively, the first transmission regions 212 and 212' are formed on side portions (e.g., on a portion of an edge extending along the first direction D1 and nearest the second transmission regions 222 and 222') of the first sub-pixels 21 and 21', and the third transmission regions 232 and 232' are formed on other side portions (e.g., a portion of an edge extending along the first direction D1 and nearest the second transmission regions 222 and 222') of the third sub-pixels 23 and 23'. The first transmission regions 212 and 212' and the third transmission regions 232 and 232' are formed to be symmetric with each other about the second transmission regions 222 and 222', respectively. The second emission regions 221 and 221' are each separated into a plurality of portions along the first direction D1 by the second transmission regions 222 and 222'.

[0111] Ones of the first, second, and third transmission regions 212, 222 and, 232 may be combined to form a large,

rectangular transmission region and other ones of the first, second, and third transmission regions 212', 222' and, 232' may be combined to form another large, rectangular transmission region.

[0112] Here, the first emission region 211 is adjacent to the other first emission region 211' along the first direction D1, the second emission region 221 is adjacent to the other second emission region 221' along the first direction D1, and the third emission region 231 is adjacent to the other third emission region 231' along the first direction D1. Thus, the disconnected appearance of the colors may be reduced or prevented.

[0113] FIG. 11 is a partial plan view of the embodiment shown in FIG. 10 in more detail.

[0114] According to the embodiment shown in FIG. 11, the 1-1 electrodes 214 and 214', the 2-1 electrodes 224 and 224', and the 3-1 electrodes 234 and 234' may be formed as rectangles, longer sides of which extend along the first direction D1, similar to the embodiment shown in FIG. 4. In addition, the first emission layer 215, the second emission layer 225, and the third emission layer 235 may be similar to those shown in FIG. 4. However, unlike the embodiment shown in FIG. 4, fourth transmission windows 2161 and 2161' are formed in the second electrode 216. The fourth transmission windows 2161 and 2161' of FIG. 11 are formed as the first transmission windows 217 and 217', the second transmission windows 227 and 227', and the third transmission windows 237 and 237' of FIG. 4 connected to each other along the second direction D2. By forming the fourth transmission windows 2161 and 2161' in the second electrode 216, the first transmission units 218 and 218' may be formed on regions of the 1-1 electrodes 214 and 214', the second transmission units 228 and 228' may be formed on regions of the 2-1 electrodes 224 and 224', and the third transmission units 238 and 238' may be formed on regions of the 3-1 electrodes 234 and 234'. In the present embodiment, a region is any region or portion except for end portions in the first direction D1 of any of the 1-1 electrodes 214 and 214', the 2-1 electrodes 224 and 224', and the 3-1 electrodes 234 and 234', and is not limited to a location in the exact or direct center of the 1-1 electrodes 214 and 214', the 2-1 electrodes 224 and 224', and the 3-1 electrodes 234 and 234' in either the first or second direction D1 or D2.

[0115] The embodiment shown in FIG. 12 may be formed by using the 1-1 electrodes 214 and 214', the 2-1 electrodes 224 and 224', and the 3-1 electrodes 234 and 234' similar to those shown in FIG. 11. That is, 1-1 openings 2141 and 2141' formed in the 1-1 electrodes 214 and 214' may open toward the 2-1 electrodes 224 and 224' (e.g., extend across edges of the first emission regions 211 and 211' extending along the second direction D2 and nearest the second emission regions 221 and 221'), 3-1 openings 2341 and 2341' formed in the 3-1 electrodes 234 and 234' may open toward the 2-1 electrodes 224 and 224' (e.g., extend across edges of the third emission regions 231 and 231' extending along the second direction D2 and nearest the second emission regions 221 and 221'), and 2-1 openings 2241 and 2241' may be formed in a portion except for a portion including an edge of the 2-1 electrodes 224 and 224' (e.g., may be formed in center portions of the 2-1 electrodes 224 and 224'). In this case, even when the 1-1 electrodes 214 and 214', the 2-1 electrodes 224 and 224', and the third electrodes 234 and 234' are formed as reflective electrodes, the external light transmittance in the transmission regions may not be largely degraded.

[0116] In addition, as shown in FIG. 7, openings corresponding to the above described openings may be formed in the passivation layer 114, or be openings formed in the inter-insulating layer 113, the gate insulating layer 112, and/or the buffer layer 111 at the portion corresponding to the first transmission region 212.

[0117] FIG. 13 is a partial plan view of the organic emission unit 2 according to another embodiment of the present invention in more detail.

[0118] Referring to FIG. 13, the first transmission regions 212 and 212' are formed in center portions along the first direction D1 of the first sub-pixels 21 and 21', the second transmission regions 222 and 222' are located in center portions along the first direction D1 of the second sub-pixels 22 and 22', and the third transmission regions 232 and 232' are located in center portions along the first direction D1 of the third sub-pixels 23 and 23', unlike the embodiment shown in FIG. 10. Accordingly, the disconnected appearance of a display due to the separation of the first sub-pixels 21 and 21' along the first direction D1 may be reduced. Likewise, the second sub-pixels 22 and 22' and the third sub-pixels 23 and 23' may not appear to be disconnected.

[0119] FIG. 14 is a partial plan view of the organic emission unit 2 according to another embodiment of the present invention in greater detail.

[0120] Referring to FIG. 14, each of the first emission regions 211 and 211' are separated into a plurality of portions (e.g., two portions) along the first direction D1 by (e.g., based on) the first transmission regions 212 and 212', respectively, each of the second emission regions 221 and 221' are separated into a plurality of portions (e.g., two portions) along the first direction D1 by the second transmission regions 222 and 222', respectively, and each of the third emission regions 231 and 231' are separated into a plurality of portions (e.g., two portions) along the first direction D1 by the third transmission regions 232 and 232', respectively. Accordingly, the external light transmittance of the organic emission unit 2 may be improved, and the disconnected appearance of colors along the first direction D1 may be reduced.

[0121] Although not shown in FIG. 14, 1-1 electrodes, 2-1 electrodes, and 3-1 electrodes may be formed as rectangles, longer sides of which extend along the first direction D1, as shown in FIGS. 4 and 11, and the second electrode 216 may be patterned or formed to correspond to the first transmission regions 212 and 212', the second transmission regions 222 and 222', and the third transmission regions 232 and 232'. However, the present invention is not limited thereto, and the 1-1 electrodes, the 2-1 electrodes, and the 3-1 electrodes may be formed similar to the 2-1 electrodes 224 and 224' and the 2-1 openings 2241 and 2241' shown in FIGS. 11 and 12. Moreover, the second opening 1141 may be formed in the passivation layer 114 as shown in FIG. 7.

[0122] FIG. 15 is a partial plan view of the organic emission unit 2 according to another embodiment of the present invention in more detail.

[0123] Referring to FIG. 15, fourth sub-pixels 24 and 24' emit light of a fourth color that is different from the first through third colors and are disposed (e.g., located) adjacent to the third sub-pixels 23 and 23', respectively, along the second direction D2, in addition to having a structure similar to that shown in FIG. 3. The fourth sub-pixels 24 and 24' are arranged along the first direction D1 to form one column line. The fourth color light may be white.

[0124] The fourth sub-pixels 24 and 24' respectively include fourth emission regions 241 and 241' and fourth transmission regions 242 and 242'. The fourth emission regions 241 and 241' emit light of the fourth color, and external light transmits (e.g., without emitting light) through the fourth transmission regions 242 and 242'.

[0125] The fourth emission region 241 of the one fourth sub-pixel 24 and the fourth emission region 241' of the other fourth sub-pixel 24' are adjacent to each other in the first direction D1.

[0126] Other components are similar to those shown in FIG. 3, and descriptions thereof are omitted here.

[0127] As described above, the embodiment shown in FIG. 15 illustrates a structure in which one pixel includes four sub-pixels emitting different color light, for example, red, green, blue, and white, and the structure in which the one pixel includes four sub-pixels may be applied to the embodiments shown in FIGS. 8 through 10, 13, and 14.

[0128] While the present invention has been particularly shown and described with reference to embodiments thereof, it will be understood by those of ordinary skill in the art that various changes in form and details may be made therein without departing from the spirit and scope of the present invention as defined by the following claims and their equivalents.

What is claimed is:

1. An organic light emitting display device comprising:
  - a plurality of first sub-pixels arranged adjacent to each other along a first direction, each of the plurality of first sub-pixels comprises a first emission region configured to emit light of a first color and a first transmission region configured to transmit external light, wherein the first emission regions of at least two of the plurality of first sub-pixels are adjacent to each other; and
  - a plurality of second sub-pixels arranged adjacent to each other along the first direction and adjacent to corresponding ones of the plurality of first sub-pixels along a second direction crossing the first direction, each of the plurality of second sub-pixels comprises a second emission region configured to emit light of a second color different from the first color and a second transmission region configured to transmit external light, wherein the second emission regions of at least two of the plurality of second sub-pixels are adjacent to each other.
2. The organic light emitting display device of claim 1, wherein the first transmission region of one of the plurality of first sub-pixels and the second transmission region of a corresponding one of the plurality of second sub-pixels are adjacent to and separated from each other along the second direction.
3. The organic light emitting display device of claim 1, wherein at least one of the first and second transmission regions is an island.
4. The organic light emitting display device of claim 1, wherein the first transmission region of one of the plurality of first sub-pixels and the second transmission region of a corresponding one of the plurality of second sub-pixels are adjacent and connected to each other along the second direction.
5. The organic light emitting display device of claim 4, wherein the first emission region of one first sub-pixel is divided by the corresponding first transmission region.
6. The organic light emitting display device of claim 4, wherein the second emission region of one second sub-pixel is divided by the corresponding second transmission region.

7. The organic light emitting display device of claim 1, wherein the first transmission region and the second transmission region have areas that are different from each other.

8. The organic light emitting display device of claim 7, wherein either the first or second sub-pixel having a light emission efficiency greater than that of the other sub-pixel has a transmission region that is larger than the transmission region of the other sub-pixel.

9. The organic light emitting display device of claim 1, wherein the first emission region and the second emission region have shapes that are different from each other.

10. The organic light emitting display device of claim 1, wherein the first transmission region and the second transmission region have shapes that are different from each other.

11. An organic light emitting display device comprising:

a plurality of first pixel circuit units;

a plurality of 1-1 electrodes adjacent to and separated from each other along a first direction, each of the plurality of 1-1 electrodes are electrically coupled to a corresponding one of the plurality of first pixel circuit units;

a first emission layer on the plurality of 1-1 electrodes, the first emission layer configured to emit light of a first color;

a plurality of second pixel circuit units;

a plurality of 2-1 electrodes adjacent to and separated from each other along the first direction and adjacent to corresponding ones of the plurality of 1-1 electrodes along a second direction crossing the first direction, each of the plurality of 2-1 electrodes are electrically coupled to corresponding ones of the plurality of second pixel circuit units;

a second emission layer on the plurality of 2-1 electrodes, the second emission layer configured to emit light of a second color that is different from the first color; and

a second electrode on the first and second emission layers, the second electrode comprises a plurality of first transmission units, each at a portion of a corresponding one of the plurality of 1-1 electrodes and configured to transmit external light, and a plurality of second transmission

units, each at a portion of a corresponding one of the plurality of 2-1 electrodes and configured to transmit external light.

12. The organic light emitting display device of claim 11, wherein ones of the plurality of first transmission units and corresponding ones of the plurality of second transmission units are adjacent to and separated from each other along the second direction.

13. The organic light emitting display device of claim 11, wherein at least one of the first and second transmission units is an island.

14. The organic light emitting display device of claim 11, wherein one of the plurality of first transmission units and a corresponding one of the plurality of second transmission units are adjacent and connected to each other along the second direction.

15. The organic light emitting display device of claim 14, wherein ones of the plurality of first transmission units are at an edge portion nearest an adjacent one of the plurality of second transmission units of each of the plurality of 1-1 electrodes.

16. The organic light emitting display device of claim 14, wherein ones of the plurality of second transmission units are at an edge portion nearest an adjacent one of the plurality of first transmission units of each of the plurality of 2-1 electrodes.

17. The organic light emitting display device of claim 11, wherein the first transmission units and the second transmission units have areas that are different from each other.

18. The organic light emitting display device of claim 17, wherein the first or second emission layer having a light emission efficiency greater than that of the other emission layer has a corresponding transmission unit having an area that is larger than that of the transmission unit corresponding to the other emission layer.

19. The organic light emitting display device of claim 11, wherein the first transmission units and the second transmission units have shapes that are different from each other.

\* \* \* \* \*

专利名称(译)	有机发光显示装置		
公开(公告)号	<a href="#">US20140225078A1</a>	公开(公告)日	2014-08-14
申请号	US13/970549	申请日	2013-08-19
[标]申请(专利权)人(译)	三星显示有限公司		
申请(专利权)人(译)	三星DISPLAY CO., LTD.		
当前申请(专利权)人(译)	三星DISPLAY CO., LTD.		
[标]发明人	JEUNG JUN HEYUNG KIM TAE JIN		
发明人	JEUNG, JUN-HEYUNG KIM, TAE-JIN		
IPC分类号	H01L51/52		
CPC分类号	H01L51/5221 H01L51/5206 H01L27/3218		
优先权	1020130014971 2013-02-12 KR		
其他公开文献	US9214499		
外部链接	<a href="#">Espacenet</a> <a href="#">USPTO</a>		

摘要(译)

有机发光显示装置包括沿第一方向彼此相邻布置的多个第一子像素，每个第一子像素包括被配置为发射第一颜色的光的第一发射区域和被配置的第一透射区域为了透射外部光，至少两个第一子像素的第一发射区域彼此相邻；多个第二子像素沿着第一方向彼此相邻布置，并且沿着与第一方向交叉的第二方向与多个第一子像素中的对应的第一子像素相邻，所述多个第二子像素中的每一个包括：第二发射区域被配置为发射第二颜色的光，第二发射区域被配置为透射外部光，至少两个子像素的第二发射区域彼此相邻。

